

# AN2106-12K-4G 4G AUDIO INTERCOM (ACCESS CONTROL SYSTEM)



---

**For your protection, read these instructions.**

**Keep it for future reference.**

# TABLE OF CONTENTS

IMPORTANT SAFETY INSTRUCTIONS.....	3
INTRODUCTION .....	4
PARTS LIST .....	4
INSTALLATION.....	5
HOW TO INSTALL A SLAVE INTERCOM.....	8
USING THE AN2106-12K.....	9
1 <i>Setting your call out numbers</i> .....	9
2 <i>Setting your call in numbers</i> .....	9
3 <i>App on iOS and Android download</i> .....	9
SMS/ PHONE MODE CODE .....	12
COMMAND CODES .....	13
KEYPAD COMMAND CODES .....	15
SMS INQUIRE .....	16
E-MAIL SETTINGS .....	17
CALL LIST LOG SETTING (SMS).....	17
CALL LIST DATA REPLY:.....	17
HOW TO RESET THE HARDWARE WHEN YOU FORGET YOUR PASSWORD.....	18
TROUBLESHOOTING (Q &A) .....	18
SPECIFICATION .....	19

## **AN2106-12K 4G Audio Intercom**

Thank you for purchasing the AN2106-12K audio intercom. Please read this manual carefully before using it.

Be sure to keep this manual for future reference in case any problem or question should arise.

### **Important Safety Instructions**

1. When using this AN2106-12K intercom, basic safety precautions should always be followed to reduce the risk of fire, electric shock and personal injury. Please read the following before using your equipment.
2. Follow all warnings and instructions on the product.
3. Unplug all the product connections before cleaning. Do not use liquid or aerosol cleaners. Use a damp cloth to clean.
4. Do not use this product near water.
5. Do not use this product near an area where gas leaks are possible or near explosive fumes.
6. Do not place this equipment near or over a radiator or other heat source.
7. Do not overload the wall outlet or power cord where the power adapter is installed. Doing so can cause fire or electric shock.
8. Avoid spilling liquid on this equipment, and do not insert any objects through the ventilation slots.
9. Avoid using the equipment during an electrical storm. There is a remote risk of electrical shock from lightning.

# AN2106-12K 4G Audio Intercom

## Introduction

The AN2106-12K intercom system is designed for multiple family complexes. AN2106-12K has 12 call buttons. One button is for one householder. When a visitor presses the call button on the intercom, which will connect to your phone number, whatever landline or mobile, you can speak with the visitor once you answer the call. You can open the gate from your phone remotely from anywhere, anytime.

To serve more households in the same community, you can connect AN2106S-12K and AN2106M-12K with cable, extending the system to 24 households.

The device installation is straightforward, so you don't need to spend extra installation fee. No unique installation or complicated wiring is necessary to wire with your gate or garage systems and power. Take an active SIM card to start.

## Parts List

Item	Description	Q'ty	Item	Description	Q'ty
1	AN2106-12K intercom	1	6	Mounting bracket for antenna (AN2106M-12K Only)	1
2	Power adapter	1	7	External 3-meter antenna (AN2106M-12K Only)	1
3	Terminal blocks	1	8	9 Pin cable (HL-086) (AN2106S-12K Only)	2
4	Power cable	1			
5	Operating manual	1			



Only  
AN2106M-12K



Only  
AN2106S-12K

# AN2106-12K 4G Audio Intercom

## Installation

### 1. SIM card installation (Fig 1)

- 1.1 Disconnect the 12V adaptor from the AN2106-12K
- 1.2 Remove the SIM card cover from the bottom of the unit
- 1.3 Slide the SIM card holder towards the front of the unit
- 1.4 Lift up the holder
- 1.5 Before inserting the SIM card, ensure that it is not PIN number locked. (If locked, use a mobile phone to unlock it).**
- 1.6 Insert the SIM card (Note orientation of notched corner)
- 1.7 Replace holder and slide it towards the rear of the unit to lock in place

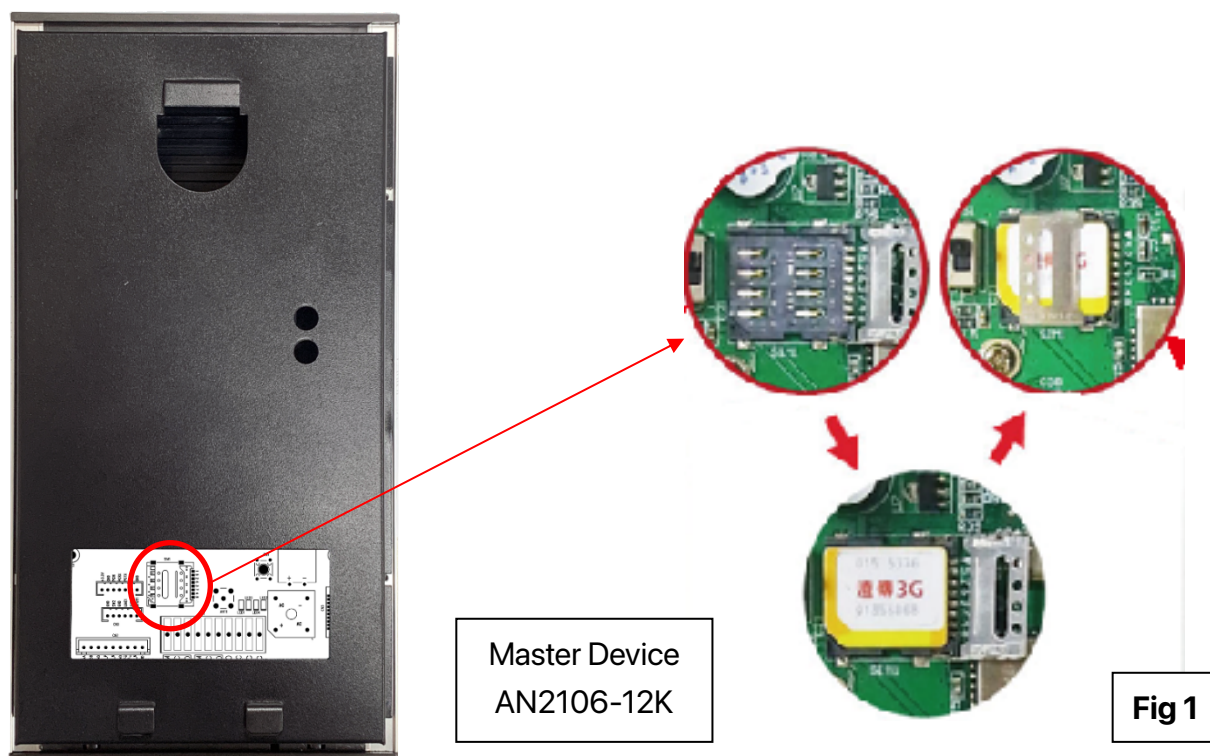

# AN2106-12K 4G Audio Intercom

## 2. Connecting with the door lock system (Fig 2)

- 2.1 According to your door lock type to wire with door latch of connector.
- 2.2 Plug on the antenna cord to the connector on the rear of the unit
- 2.3 Place antenna away from electrical/electronic systems (computers, microwave ovens, etc)

## 3. Power on and fix it well

- 3.1 Connect the power adaptor into the connector marked DC
- 3.2 The blue indicator of call button should be on, and you will hear **\*Du Du\*** tone.
- 3.3 Fix the unit on the position before ready.
- 3.4 When the **\*Du Du\*** tone has disappeared, then the Device is ready.

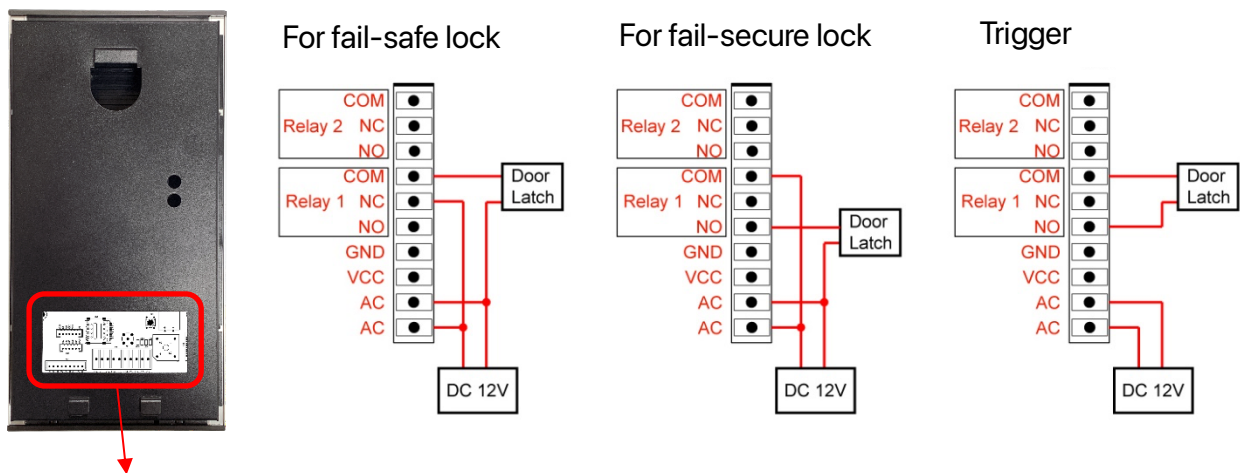

**Wiring Diagram**

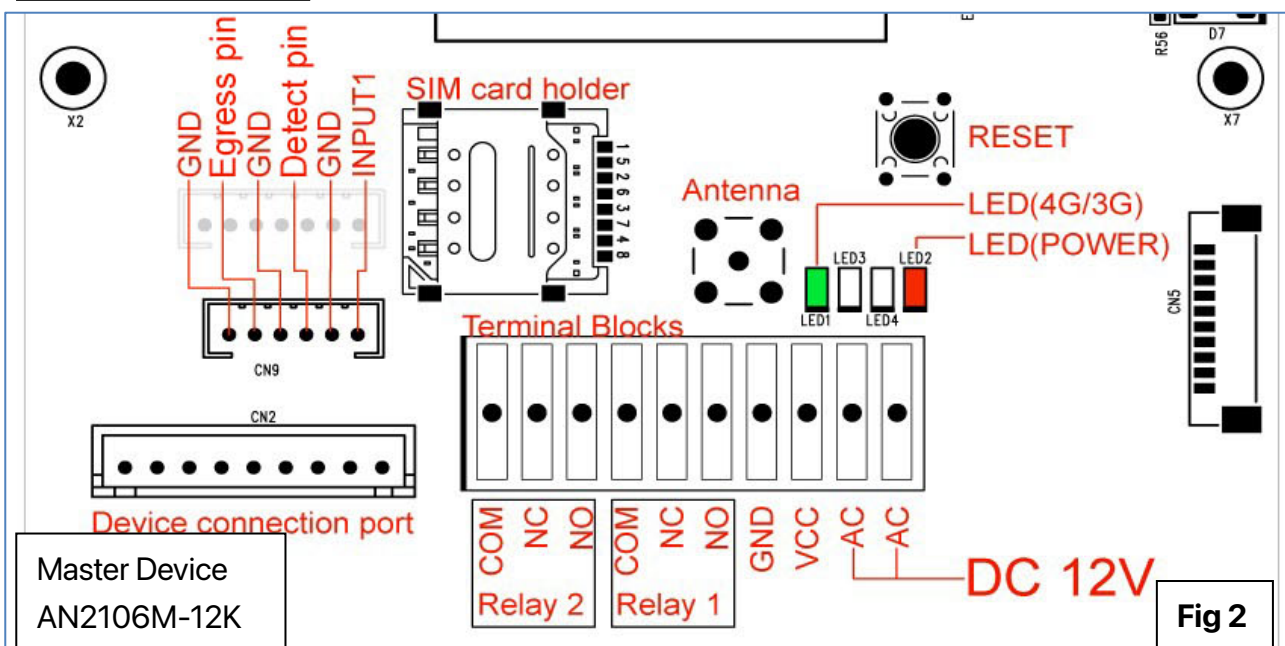

**Fig 2**

# AN2106-12K 4G Audio Intercom

4. This intercom is suitable for surface mounting.

①



②



③



④



⑤

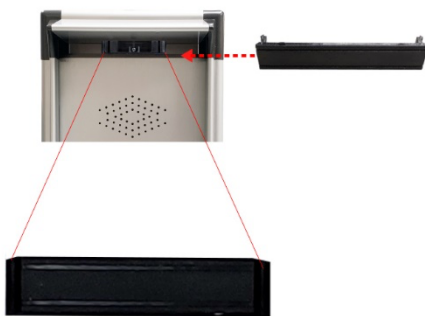

⑥



# AN2106-12K 4G Audio Intercom

## How to install a slave intercom

1. Set the rotary switch as "1" of the slave device (AN2106S-12K)

**NOTE: If you are installing multiple slave intercoms, please adjust the numbers in sequence.**



2. Connect the slave device and master device with two HL-086 together

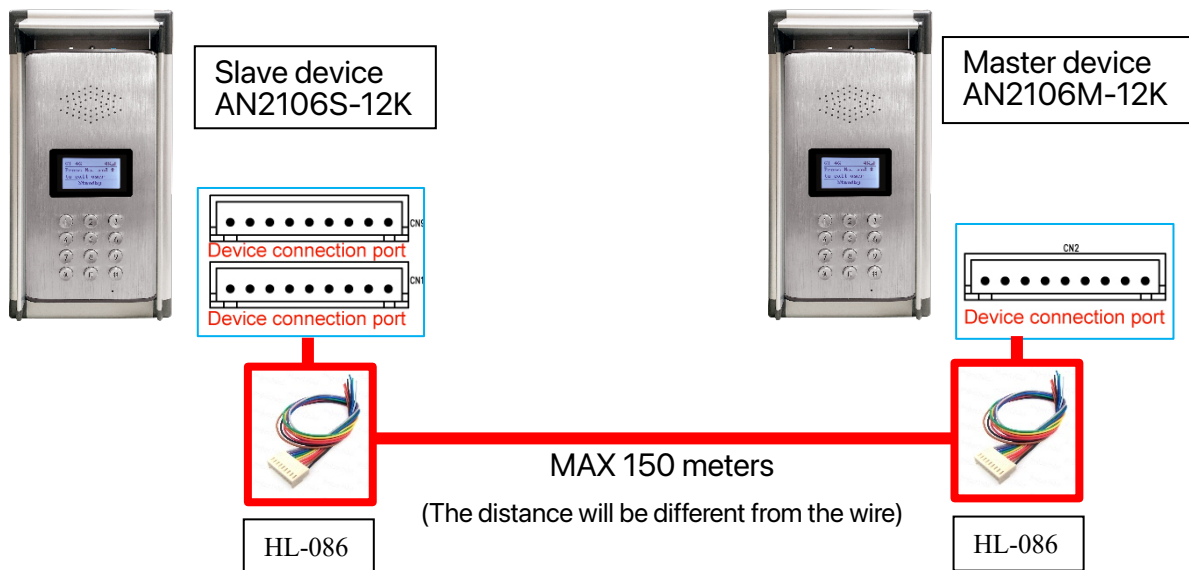

**NOTE: To ensure the system work completely, you must power on the slave device then power on the master device.**



# AN2106-12K 4G Audio Intercom

## Using the AN2106-12K

### 1 Setting your call-out numbers

- 1.1 Store your apartment NO (householder number) and your phone number by SMS.
- 1.2 SMS format: (store 3 phone numbers of an apartment **010101**)
- 1.3 \*12\*1234#**911010101**\*05857235#**912010101**\*0865682554#**913010101**\*0862235644#

#### 1.4 Check if the SMS Setting is correct

SMS reply:

**911010101**\*05857235#**912010101**\*0865682554#**913010101**\*0862235644#OK

#### 1.5 If the user command code error (user command **19** error)

SMS format:

\*12\*1234#**911010101**\*05857235#**19**0865682554#**913010101**\*0862235644#

SMS reply: **911010101**\*05857235#**19**0865682554# Error

- 1.6 The visitor **presses the "call button"**. Then, AN2106M-12K will call the three phone numbers in sequence.

### 2 Setting your call-in numbers

- 2.1 Send the text SMS to the device number.
- 2.2 The format of text SMS is  
\*12\*1234#**71**[country code] #**72**[relay] [call in number 1] # **72**[relay] [call in number 2] #...
- 2.3 When the setting is finished, the sender will receive the reply as below.  
**71**[country code] #**72**[relay] [call in number 1] # **72**[relay] [call in number 2] #...OK
- 2.4 If you call the device number through the call-in numbers, the device will trigger the relay to control the door latch and reject the call.
- 2.5 The device will answer and sound a beep if the number does not match the call-in numbers. Then, you can enter the program setting mode by password.

### 3 App on iOS and Android Download

- 3.1 Please search "**3G intercom**" on the Apple store or Google Play
- 3.2 The app can help you program the device more easily.
- 3.3 You can use the app to unlock the door by phone or SMS.

# AN2106-12K 4G Audio Intercom

## Enter System Menu

1. Please call the number of the 4G intercom device.
2. The device will answer and sound one beep to enter the system menu.
3. Enter the password of the mode you would like to enter.
  - 3.1 Listener monitoring mode: 【\*13\*1212 #】
  - 3.2 Access control mode: 【\*33\*5678 #】
  - 3.3 Program setting mode: 【\*12\* 1234 #】
4. Password correct one beep, password error 3 beeps.
5. 3 times failed attempts on the password, and the device hung up the call.

## Enter Listener Monitoring Mode

1. You will hear a "Do" tone to enter listener monitoring mode by pressing 【\*13\*1212 #】 where 1212 is the monitoring password.
2. Then, you can hear the live sound of the device's surrounding environment.
  - \* Under this mode speaker is OFF. ( **35 # : To turn on speaker** )
  - \* You can still control the relay output under listener monitoring mode, but the speaker must be ON status.

## Enter Access Control Mode

1. You will hear a "Do" tone to enter access control mode by pressing【\*33\*5678 #】 , where 5678 is the access control password.
2. The door will be opened after you enter the correct password
  - \* (To open the door by password if the number is not stored in the call-in numbers)

## Enter Program setting Mode.

1. You will hear a "Do" tone to enter program setting mode by pressing 【\*12\* 1234 #】 , where 1234 is the setting password.
2. You are now in the "program setting mode."  
**Note: At the end of each command, there can be one of the two indications:  
Successful: a long "beep" tone; failed: three short "beep" tones.**
3. To make changes to settings, please refer to the command codes on page 14.
4. To end program setting mode, just hang up.

### NOTE:

**To be successful in programming, originate a call from a land line and enter the digits slowly or using programming by text message.**

# AN2106-12K 4G Audio Intercom

## Programming by text message

Programming by text message is the simplest way to customise the 4G audio intercom settings and add or delete telephone numbers. Send texts in the format to the telephone number of the SIM within the 4G audio intercom.

### Note:

1. A Single SMS text message is limited to 140 characters.
2. You can program many user command codes in one text message with SMS command format. **\*12\*1234 # [command Code1] # [command Code 2] # [command Code3] #...**
3. Each SMS must start with the passcode \*12, the default setting password 1234 in the following format **\*12\*1234 #** followed immediately by a command.
4. To program a call button number (DO NOT enter country code), use the complete number as you dial it locally.

### Example:

Store a call button phone number (Max 3 numbers) and delete 2&3 phone numbers.

058 57235 (landline number 1)  
086 5682554 (mobile number 2)  
086 2235644 (mobile number 3)

**Command to use:**  
**\*12\*1234#91[Y][apartment No.]\* [phone number]#...**  
Y= number 1, 2 or 3  
**apartment No.: 1-6 digits**

SMS format: (store a call button phone numbers)

**\*12\*1234#911010101\*05857235#912010101\*0865682554#913010101\*0862235644#**

SMS format: (delete 2&3 phone numbers from a call button and delete apartment no. 402)

**\*12\*1234#912010101\*#913010101\*#92010101\***

### User command code CORRECT

SMS format:

**\*12\*1234#911010101\*05857235#912010101\*0865682554#913010101\*0862235644#**

SMS reply:

**911010101\*05857235#912010101\*0865682554#913010101\*0862235644# OK**

### User command code ERROR (user command 919 error)

SMS format:

**\*12\*1234#911010101\*05857235#919010101\*0865682554#913010101\*0862235644#**

SMS reply: **911010101\*05857235#919010101\*0865682554# Error**

# AN2106-12K 4G Audio Intercom

## SMS/ Phone mode code

No.	Feature	Command	NOTE:
1	Setting mode	*12*[setting password]#	<p><b>Phone mode:</b> Dial the phone and enter *12*1234 to enter the setting mode. (listen to DO), you can enter the command codes below.</p> <p><b>SMS:</b> You can program many different command codes in one text message with SMS command format. *12*1234 # [command Code 1] # [command Code 2] # [command Code 3] #.....</p>
2	Monitoring mode	*13*[setting password]#	<p><b>Phone mode:</b> Dial the phone and enter *13*1234 to enter the monitoring mode.</p> <p><b>SMS:</b> Send SMS (*13*1212#) to the device and the device will call you back</p>
3	Trigger Relay1	*33*[access control password] #	<p><b>Phone mode:</b> Dial the phone and enter *3(3, 4, 5)*5678 to (trigger, hold, release) relay1.</p> <p><b>SMS:</b> Send SMS [*3(3, 4, 5)*5678#] to the device and the device will (trigger, hold, release) relay1</p>
4	Hold Relay1	*34*[access control password] #	
5	Release Relay1	*35*[access control password] #	
6	Trigger Relay2	*36*[access control password] #	<p><b>Phone mode:</b> Dial the phone and enter *3(6, 7, 8)*5678 to (trigger, hold, release) relay2.</p> <p><b>SMS:</b> Send SMS [*3(6, 7, 8)*5678#] to the device and the device will (trigger, hold, release) relay2</p>
7	Hold Relay2	*37*[access control password] #	
8	Release Relay2	*38*[access control password] #	

# AN2106-12K 4G Audio Intercom

## Command Codes

You can program many command codes in one text message with SMS command format.

\*12\*1234 # [command Code1] # [command Code 2] # [command Code3] #.....

No.	Feature	Command	Description	Default
1.	Change setting Password	01 [ password ] #	password:4 digit codes	1234
2.	Change access control password	02 [ password ] #	password:4 digit codes	5678
3.	Change monitoring password	03 [ password] #	password:4 digit codes	1212
4.	Digits for apartment No.	909[X]#	X=1~6 digits	6
5.	Store or delete an apartment phone numbers	91 [ Y ] [X]*[ phone number ] #	Y= phone number 1,2,3,4 or 5 X= householder NO. Phone number= 3-20 digits (One * can be delay 3 seconds)	None
		91 [ Y ] [X]* #	Delete apartment phone number	
6.	Delete an apartment No.	92 [X]#	X= apartment number	None
7.	Speaker Volume	3 [ speaker volume] #	speaker volume level= 0 ~ 4	3
8.	Microphone Volume	4 [ microphone volume] #	microphone volume level= 0 ~ 4	3
9.	Relay 1 Trigger Time	51 [ relay1 time ] #	Relay 1 time= 1~9999 sec	1
10.	Relay 2 Trigger Time	50 [ relay 2 time ] #	Relay 2 time= 1~9999 sec	1
11.	Call Divert to next number time	52 [ call divert time ] #	Call divert time= 10~99 sec	20 sec
12.	Max Call Time	53 [ max call time] #	Max call time= 005~999 sec	060 sec
13.	Max Monitoring time	55[ duration time] #	duration time= 00 ~ 60 mins 00 ( no limit time)	10 mins
14.	Call in mode	65[mode]#	mode = 1 Setting mode mode = 2 Call mode mode = 3 Reject mode (caller ID permit)	1
15.	Call in to open the door numbers (Max: 1500 numbers)	71 [ country code ] #	Country code= 1~3 digit codes	None
		72[relay] [ phone number ] #	Relay= 1 or 2	
		73 [phone number ] #	Delete phone number	
		73*#	Delete all phone numbers	
16.	Add administrator phone number	74 [ admin number ] #	admin number= 3~15 digits ( no number no restriction)	None
17.	Del administrator phone number	74*#	delete admin phone number	None
18.	Call list reply type	84+X#	X=0:no reply X=1:SMS X=2:E-mail Original setting 1 or 2, changing to 0 will delete "Call list" content	0
19.	Call list reply number(type: SMS)	85 [reply number ] #	reply number=3~15digits	None
20.	Dele call list reply number	85*#	Dele call list reply number	None
21.	SMS reply notice of Relay status	894+X#	X=0 (disable SMS reply) X=1 (enable SMS reply)	0
22.	Dial tone volume	898+X#	X=1~3 ( levels)	2
23.	Set Egress Pin output relay	900[X]#	X=0 (relay 1) X=1 (relay 2)	0

## AN2106-12K 4G Audio Intercom

24.	Set Detect pin output relay (Detect Pin is egress mode)	901[X]#	X=0 (relay 1) X=1 (relay 2)	1	
25.	Detect pin on PCB setup	902[X]#	X=0~3 0: disable 1: egress mode (901) 2: trigger 3. Resistance=10KΩ(7.5K~13K)	0	
26.	Emitting bleep when correct PIN code entered	903+X#	X=0 (disable) X=1 (enable)	1	
27.	Intercom moving Detection (Theft Proof)	904[X]#	X=0 (disable) X=1 (enable)	0	
28.	Set Alert phone number (moving & trigger)	905[ Y ][ phone number ] #	Y= phone number 1,2 or 3 Phone number=3~15 digits	None	
29.	Enable or disable IN1	907[X]#	X=0 (disable) X=1 (enable)	0	
30.	Change the length of open code	940[X]#	X=1 (1 code open code) X=2 (2 codes open code)	1	
31.	Change open codes of relay 1&2 including trigger / hold / release for independent apartment	93[X]*[ABCDEF]#	X= apartment number A,B,C,D,E,F= 0~9 and * A= trigger relay 1 B= hold relay 1 C= release relay 1 D= trigger relay 2 E= hold relay 2 F= release relay 2	1	2
				cod	cod
				e	e
				1	10
				1	10
1	10				
4	40				
4	40				
4	40				
32.	Enable or disable IN1	907[X]#	X=0 (disable) X=1 (enable)	0	
33.	Send SMS message (when Detect Pin is triggered)	*26*[ password ]#[content]	Password=setting password content= up to 100 characters	Detect PIN Trigger	
34.	Send SMS message (when Intercom is moved) Send SMS message (when external power is off ) (works for inside battery)	*27*[ password ]#[content] *28*[ password ]#[content]	Password=setting password content= up to 100 characters Password=setting password content= up to 100 characters	Case open	
				Power loss	
35.	Send SMS message (when external power is active) (works for inside battery)	*29*[ password ]#[content]	Password=setting password content= up to 100 characters	Power active	
36.	Send SMS message (when IN1 is triggered)	*30*[ password ]#[content]	Password=setting password content= up to 100 characters	IN1 trigger	
37.	Reset	999#	reset default	None	

# AN2106-12K 4G Audio Intercom

## Keypad command codes

No.	Feature	Command	Description	Default
1	Set PIN length for auto enter	899+X#	X=1~14	5
2	Set PIN code Type	895+X#	X=0, only digits X=1, apartment no. with digits	0
3	Store PIN code (Max: 1000 sets)	87+ [relay][pin code]#	relay=1: relay1 trigger relay=2: relay1 hold/ release relay=3: relay2 trigger relay=4: relay2 hold/ release pin code= 1~14 digits	Empty
4	Delete PIN code	88+[relay][pin code]#	Relay=1~4	
5	Delete all PIN code	88*#		
6	PIN code failed attempt times	890+X#	X=0~9 (times) X= 0 (failed attempt no limit)	5
7	Time stop entering pin code after constantly failed attempt	892+X# · 1~99分	X=1~ 99 (minutes)	1
8	Set PIN code error alarm buzzer	893+X#	X= 0, disable (keypad flashing) X= 1, enable alarm buzzer	1
9	Set keypad LED indicator	897+X#	X=0 (LED ON) X=1 (LED OFF)	0

# AN2106-12K 4G Audio Intercom

## SMS Inquire (only one format per seal, length limit 140)

No.	Feature	Command	Reply content	
1	Check signal strength	*20#	Operator name , Network Signal Level = X	
			Network : GSM/WCDMA X= 0~31 · 0 : poor 31 : strong	
2	Check device save number	*21#	I+Call in(TEL),.....E(N)	
			I : Call in number E : End N : Next SMS	
3	Check the RELAY status	*22#	Relay1=(status),Relay2=(status),Detect=(Input),I N1=(Input)	
			status: hold/release/trigger Input: ON/OFF	
4	Multiple households call list and opening number	*31*setting password# household number#	<b>reply:</b> <b>N number – 1, 2, 3, 4, 5, 6</b> <i>1 Trigger Relay1</i> <i>2 Hold Relay1</i> <i>3 Release Relay1</i> <i>4 Trigger Relay2</i> <i>5 Hold Relay2</i> <i>6 Release Relay2</i>	
			1-TEL1 [If not set, only display 1-] 2-TEL2 [If not set, only display 2-] 3-TEL3 [If not set, only display 3-]  apartment No.: 1~6 digits <b>If no account number is added, return all the number and phone number</b>	
5	Send SMS message (when Detect Pin is triggered)	*26*[ password ]#[content]	Password=setting password content= up to 100 characters	Detect PIN Trigger
		*26*[ password ] #	Query current message content	
6	Send SMS message (when Intercom is moved)	*27*[ password ]#[content]	Password=setting password content= up to 100 characters	Case open
		*27*[ password ] #	Query current message content	
7	Send SMS message (when external power is off ) (works for inside battery)	*28*[ password ]#[content]	Password=setting password content= up to 100 characters	Power loss
		*28*[password]#	Query current message content	
8	Send SMS message (when external power is active) (works for inside battery)	*29*[ password ]#[content]	Password=setting password content= up to 100 characters	Power active
		*29*[password]#	Query current message content	
9	Send SMS message (when IN1 is triggered)	*30*[ password ]#[content]	Password=setting password content= up to 100 characters	IN1 trigger
		*30*[password]#	Query current message content	



# AN2106-12K 4G Audio Intercom

## E-mail settings

No.	Feature	Command
1	GPRS setting	NOTE: AUTH_type:0: none 1: PAP 2: CHAP *40*setting password#APN, AUTH_type, APN User name, APN Password#
2	E-mail setting	NOTE: Type: 1: Normal 2: SSL/TLS *41* setting password #type, SMTP server, Port, User name, Password, E-mail address, E-mail sender name#
3	Recipient & copy. Can be no set, but (,) to keep	*42*setting password# normal recipient address, Recipient name, Carbon Copy recipient, Recipient name#
4	Letter subject	*43*setting password#E-mail subject#
5	Instant return (send Email)	*44*setting password# SUCCESS (Mail sent) FAIL

## Call list log setting (SMS)

- Send the text SMS to the number of devices.
- The format of text SMS is  
\*12\*[setting password]#841#85[Call list reply number]#
- When the setting is finished, the sender will receive a TEXT reply as below:

P.S. When the dial-in number log records 100 calls, it will SMS immediately to reply number

P.S. To immediately send current dial-in numbers log via email or SMS, The format of text SMS is \*44\*[setting password]#

Call list Example:

```
001@09/02/21,13:50:45- S
10968297738-1#
002@09/02/21,13:50:45- O
10968297738-2#
003@09/02/21,13:50:45- I
10968297738-3#
```

841#85[Call list reply number]#OK

## Call list data reply:

NO.	@	MM/DD/YY	,	Hh:mm:ss	-	Code	Relay	Number	-	Relay status	#
-----	---	----------	---	----------	---	------	-------	--------	---	--------------	---

Code:	Relay:	Number:	Relay status:
O: incoming call without action	0: no relay	- Phone number	1: relay 1 trigger
I: incoming call to trigger relay	1: relay 1	- Householder number* stored	2: relay 1 hold
P: PIN code to trigger relay	2: relay 2	- PIN code	3: relay 1 release
M: monitor call to activate relay			4: relay 2 trigger
R: incoming call and enter password to activate relay			5: relay 2 hold
S: SMS to activate relay			6: relay 2 release
T: during the call, householder to activate relay			

# AN2106-12K 4G Audio Intercom

## How To Reset the Hardware When You Forget Your Password

1. Keep both the reset and egress buttons pressed
2. Release all buttons after you hear continuous “Dou” tones
3. The device will restart, and the hardware reset will be done

## Troubleshooting (Q &A)

### **Q. The unit keeps bleeping.**

A. This means the unit cannot detect the network for some reason.

-Check the SIM card is activated and has calling credit.

-Power off the unit, remove the SIM and check it on a mobile phone to verify it can make a call.

-Check if the PIN code of the SIM is disabled when put in a phone.

-Check the reception is good. Poor reception is not sufficient.

-Check that the antenna has been mounted as high as possible and not near large metal objects, wet green shrubs, etc.

### **Q. The unit calls the first number, but there is insufficient time to answer before it diverts to the following number.**

A. Increase the no-answer time as per programming instructions.

### **Q. The unit calls the first number, but voicemail comes on before it can ring the second number.**

A. Decrease the no-answer time as per programming instructions.

### **Q. The caller ID part does not work.**

A. Be sure to program the caller ID part under 72 features. If your number is private or the number is withheld, then it will not work.

Even if you have already programmed a number to receive a call from the intercom, if you also want that number to have caller ID access, it must be programmed under the 72 features.

Ensure the number is entered as you usually dial it from another phone.

## AN2106-12K 4G Audio Intercom

### Q. There is no audio from the gate, but the person at the gate can hear ok.

A. This can be due to low reception.

-Check reception level by \*20#.

-Change the SIM card if another network has better coverage.

-Purchase a high-gain antenna.

### Q. The audio quality that can be heard on the remote telephone is poor or humming (buzzing).

A. A small amount of GSM buzz can be considered standard on 4G audio intercoms, but not so much that it makes it impossible to hear the person speaking. This can be caused by the GSM antenna being mounted too close to the speech panel or not high enough.

-Try earthing the speech panel chassis to 0V of the power supply.

-This is also a symptom of poor reception. Try the above steps to check and improve reception.

### Q. The 1 or 2 keys do not work when the intercom calls a phone.

A. Check if you can hear the relay clicking at the gate when the 1 or 2 key is pressed during a call. The system works if it can be heard; check the wiring between the relay and the lock or gate panel. If the relays do not make a clicking sound, then check this feature on a different mobile cell phone or landline. If it works on a different phone, check the settings under DTMF tones on the phone in question. Failure of DTMF tones to operate correctly is also a symptom of low reception. Check the steps above on improving reception. Try pressing the buttons longer when attempting to activate the gates or door.

## Specification

Model	AN2106-12K 4G/3G Audio Keypad Intercom
GSM / WCDMA / 4G Frequency	2G / GSM 850/900/1800/1900 MHz, 3G / WCDMA 800/850/900/1900/2100 MHz 4G / LTE (EC) LTE FDD: B1/B3/B7/B8/B20/B28A 4G / LTE (A) LTE FDD: B2/B4/B12 4G / LTE (AU) LTE FDD: B1/B2/B3/B4/B5/B7/B8/B28 LTE TDD: B40
Face plate	262 (H) x 138 (W) mm
Surface back box	324 (H) x 177 (W) x 71(D) mm
Length of antenna	3 meters cable
Power supply	12~24V AC/ DC
Design and material	Vandal resistant / die cast aluminum
Humidity	Less than 80% RH
Operating Temperature	-20°C to 50°C
Operating Current	Maximum 250 mA, Typically 55mA